

CONCEPTS FOR LEAN LABORATORY ORGANIZATION KONCEPT ORGANIZACIJE LEAN LABORATORIJE

Gabriele Halwachs-Baumann

Department for Laboratory Medicine, Central Hospital Steyr, Steyr, Austria

Summary: In the last decades, hospital laboratories are beset on all sides by demands to lower the costs of laboratory procedures and at the same time to provide (i) more rapid and usable services, (ii) a broader spectrum of parameters, and (iii) process a higher frequency of specimens. These demands are voiced by patients, physicians, hospital administrators, and governmental agencies. Thus, laboratory management is required to decrease costs, increase efficiency, and promote customer satisfaction under the consideration of quality to be of primary importance. Beside the main task of a laboratory (i.e. the analysing of patient specimens, interpretation of results, expert advice for clinicians), quality management, education of technicians and medical staff, research and development, and development of economic strategies are important duties and responsibilities. A lean laboratory organisation is an important condition to cope these duties. Lean laboratory concepts have to include the preanalytical, analytical and postanalytical period. Strategic planning decisions have to be based primarily on information derived from the external environment and have to be long-term. Lean laboratory concepts always have a holistic view, including medical demands and economic aspects. An example will be shown of how lean laboratory concepts influence the organisation, efficacy and performance of a hospital laboratory.

Keywords: automatization, Lean laboratory

Kratak sadržaj: U poslednjih nekoliko decenija, bolničke laboratorije suočene su sa zahtevima za smanjenje troškova laboratorijskih postupaka i istovremeno i) pružanje bržih i dostupnijih usluga i ii) obrađivanje šireg spektra parametara i iii) veće frekvencije uzoraka. Ovi zahtevi potiču od pacijenata, lekara, bolničkih uprava i vladinih agencija. Tako se od uprave laboratorije očekuje da snizi troškove, poboljša efikasnost i omogući zadovoljstvo klijenata, pri čemu kvalitet ima presudnu ulogu. Pored glavnih poslova laboratorije (npr. analiziranje uzoraka pacijenata, tumačenje rezultata, stručno savetovanje kliničara), važni zadaci i odgovornosti tiču se upravljanja kvalitetom, edukacije tehničara i medicinskog osoblja, istraživanja i razvoja, kao i razvijanja ekonomskih strategija. Organizacija »Lean« laboratorije važan je uslov za uspešno obavljanje tih zadataka. Koncept »Lean« laboratorije mora obuhvatiti preanalitički, analitičku i postanalitičku fazu. Strateške odluke o planiranju moraju biti dugoročne i pre svega zasnovane na informacijama iz spoljašnje sredine. Koncept »Lean« laboratorije uvek podrazumeva holistički pristup, koji uključuje medicinske zahteve i ekonomske aspekte. Biće dat primer na koji način koncept »Lean« laboratorije utiče na organizaciju, efikasnost i delatnost bolničke laboratorije.

Ključne reči: automatizacija, »Lean« laboratorija

Introduction

Laboratory testing is an integral part of the decision-making process, and results of laboratory testing often strongly influence medical diagnoses and therapy. In about 65% of cases the clinical

Address for correspondence:

Univ. Prof. Prim. Dr. Gabriele Halwachs-Baumann
Department of Laboratory Medicine
Central Hospital Steyr
Sierningerstrasse 170
4400 Steyr, Austria
Phone: +43 (0)5055466 25300
Fax: +43 (0)5055466 25304
e-mail: gabriele.halwachs-baumann@gespag.at

Abbreviations: GDP: gross domestic product, STAT: short turn-around time; POCT: point of care testing, FTE: full time equivalent

laboratory is essential for the determination of diagnosis (1, 2). In contrast to this, the costs for laboratory diagnosis are nowadays only 1.5–2.5 % of the total health expenditures (3, 4). That means a reduction of cost of about 2 percent points in the last ten years (i.e. in the mid nineties the laboratory costs were about 3.5–5 % of the health expenditures) (5–7).

Since health expenditures all over the world increase continuously (Table I), politicians and thus the management of hospitals demand reduction of cost. Irrespective of the low share of expenses the hospital lab is often blamed for costs too much, and outsourcing to an outside lab seems to be the solution to that problem. Although that might bring a short-dated benefit, for longer periods the expenditures can be expected to rise, due to increasing consequential charges at clinical departments (longer hospitalization of patients, increasing application of blood products, etc.) and increasing STAT and POCT services. To avoid this undesirable development, the challenge for the lab and hospital is to evaluate critically the situation and to remedy systemic problems inside the hospital, so that they would be able to compete with outside labs.

Along the pressure to contain cost and operate efficiently, regulatory requirements, health-care trends and technological/equipment advances significantly influence changes in clinical laboratories (8, 9). Beside the main tasks of a laboratory (i.e. the analysing of patient specimens, interpretation of results, expert advice for clinicians), quality management, education of technicians and medical staff, and research and development are important duties and responsibilities. In a 2004 study (8) the top five reasons impacting change in the clinical laboratory were the need to (10):

1. reengineer workflow
2. decrease turnaround times
3. reduce errors in testing or reporting
4. have availability of qualified staff
5. increase outreach.

So the lab manager has the problem of squaring the circle: to process a higher frequency of specimens and a broader spectrum of parameters and at the

same time reduce costs, but comply with the increasing demand for quality and reduced turnaround time. And all that has to be performed by less staff. Lean Laboratory Organization is an important condition to cope with this »lab paradox«.

What does »Lean Laboratory Organization« mean?

»Lean Laboratory Organization« is based on »Lean Thinking«, a management system whose origins lie in post-World War II Japan. At that time Toyota developed the Toyota Production system, with its pillars of »Just in Time« and »Built-in-Quality« (11). The goal of Lean Thinking is »the endless transformation of waste into value from the customer's perspective«, where waste is »anything that does not add value to the final product or service, in the eyes of the customer«, and value is »the capability to deliver the product to the customer, at the right time and at an appropriate price« (11). These principles can be transferred to health systems, amongst others the clinical laboratory (11–13). To avoid waste will not only improve quality, it will also save money. It has been estimated that waste accounts for 30 % to 50 % of health care spending (14, 15).

Lean laboratory concepts always have a holistic view, including medical demands and economic aspects. Strategic planning decisions have to be based primarily on information derived from the external environment and have to be long-term. The demands of the customer have to be fulfilled completely and economically. So, the view on the laboratory has to be changed: the internal view has to be replaced by an external view. The first thing that must be done is defining the customers and their needs. A department for solid organ transplantation has other requirements than a department for orthopaedics. Intensive care units have different needs compared to rehabilitation clinics. These needs influence the work in the lab by defining parameter spectrum, expected turnaround time, and sample size. On the other hand the lab influences the work in the clinical departments by influencing the time since diagnosis and therapy, guidance of therapy and length of hospital stay (16–18). Second, you have to measure the initial situation. Many hospital labs are certified or accredited to the EN ISO standards (e.g. EN ISO 15189:2003 Medical laboratories – particular requirements for quality and competence). These standards provide a good toolset for measuring processes and quality. The major process in a lab is the way of a specimen tube through the lab. To visualize this process allows the next step – analyzing this process. An essential Lean laboratory organization tenet is to keep the specimen tubes moving, avoiding periods when a specimen sits around waiting for the next step in the process. Creating a scoring system for parameters reflecting the urgency of their

Table I Total expenditure on health (% GDP) in some OECD member states (www.oecd.org)

	1998 (% GDP)	2008 (% GDP)
Austria	10.0	10.5
Germany	10.2	10.5
Slovenia	7.9	8.3
Slovak Republic	5.7	7.8
United Kingdom	6.7	8.7
United States	13.4	16.0

processing allows reengineering and improving this process. And last, but not least, control the process. This course of action is called the DMAIC-roadmap (Define-Measure-Analyze-Improve-Control) (19).

Beside the explanation of what lean laboratory organization means, it is also important to define what lean laboratory organization does not mean. Lean laboratory organization is not about head count reduction. It is about being able to do more, improving patient care with existing resources (20). Lean laboratory organization is not about making people work harder and faster. On the contrary – lean laboratory organization should enable the employees to work at a smooth, comfortable pace, without interrupting pressure and stress (21).

Laboratory automation

Lean Laboratory Organization and automation fit together quite well provided that two requirements are fulfilled:

1. Automation is a tool not a solution.
2. Do not automate waste.

So, automation must always be based on an improvement of the process. Thus, the goal of a successful automation project must be to change the way in which the laboratory's work is done. This involves changing not only tools and processes, but also jobs, structure, and ultimately, the way people think about their work (22). Reasonable automation provides improved efficiency coupled with reduction in processing errors (7), improved turnaround times, automated repeat and reflex testing, enhanced safety, and improved specimen tracking (23). This sounds quite similar to the definitions and topics of lean laboratory organization.

There exist various types of automation (10, 24, 25).

(i) *Total laboratory automation*: this term is now commonly used to describe automation that includes a preanalytical system connected to one or more modular analytical systems on one continuous line using a track design.

(ii) *Modular laboratory automation*: this term refers to a system that incorporates some automation pieces, although not everything is connected.

(iii) *Workcell/workstation automation*: this type is similar to modular automation. It may include items involved in the preanalytical phase and have some analytical departments placed on an automated line. Nevertheless, some samples still need to be manually sorted and taken to departments that are not part of the workcell line for testing.

The appropriate choice of automation technology depends on the needs and on the infrastructure

of the laboratory and will certainly not be the same for all laboratories (22). Even for various departments of a laboratory the automation requirements can differ.

Nevertheless, laboratory automation involves much more than a robotic system within a laboratory. Automation design philosophy has evolved from a hardware-based approach to a software-based approach (7). The laboratory information system (LIS) has a crucial part for the function of automation. It is involved in both analytical and »peri-analytical« processes. The latter includes both preanalytical processes, such as processing of physicians' orders and specimen accessioning, and postanalytical processes, such as result verification and report generation (23). Very often attention is turned to the preanalytical processes, which are supported by the automation either as part of total laboratory automation or as stand alone solution, and the postanalytic processes are unattended. But automation very often results in consolidation of multiple disciplines (e.g. clinical chemistry and immunology), and thus the amount of results produced by an automation system increases enormously. Automated data reporting (also known as autoverification) can help to deal with this pack of data. By this process a computer verifies patient results by applying mathematical algorithms and delta checks, reviews coded comments, and performs data mining. This frees up technical staff to focus their attention on tests that require further investigation or manual confirmation (10). Benefits of autoverification are reduced fatigue associated with reviewing data, reduced errors from overlooked abnormal results, increased patient safety, improved laboratory quality, reduced turnaround time (10).

Beside LIS architecture is an important basis for a well-functioning lab. Modern laboratory design, as it began in the late 19th century, is characterized by a modular arrangement of benches, cabinets, and fume hoods. The primary assumption of this system is that most laboratory activities involve the manipulation of materials and apparatus at the bench by fixed casework and small apparatus. Over time, this rigid ergonomic module has been abandoned for open plan settings more conducive to the use of large analyzers. This was done in many cases at the expense of the rational coordination of laboratory utilities. As the rational planning module has lost importance, so too have many of the traditional boundaries between disciplines. The result, if not carefully controlled, often is a clinical laboratory whose ad hoc planning mirrors that of many of the older hospitals (26, 27).

Reorganizing the lab department: a hospital case study

The central hospital Steyr consists of 2 sites. The larger one with 700 beds is located in Steyr (a town

with 40.000 inhabitants). It consists of 21 clinical departments, including an interdisciplinary intensive care unit (internal medicine, neurology, pulmonary disease) and an intensive care unit at the department of anaesthesiology. Beside these, a department of neonatology and children disease, a department of internal medicine (cardiology, nephrology and dialysis, gastroenterology, oncology, etc.), a department of general surgery and one for trauma surgery exist, as well as others like ophthalmology, psychiatry and ear-nose and throat, etc. There are a 24-hour, 7d/week emergency department and 22 outpatient centres. About 40.000 inpatients and 300.000 outpatients are treated per year. The smaller site is located in Enns (11.000 inhabitants), and consists of a department of internal medicine, including a small intensive care unit, and a department of psychosomatic medicine.

The department of laboratory medicine at the central hospital Steyr consists of a 24-hour, 7d/week core lab (clinical chemistry, immunology, haematology, haemostaseology, urine diagnosis), including a blood bank, and special divisions for molecular diagnostics, chromatographic determination of drugs and endocrinological parameters, and autoimmune diagnostics. In the 20 km dislodged hospital site in Enns a STAT lab is located.

In 2006 the process of reorganisation of the department of laboratory medicine began, including

- architectural planning of a new lab
- homogenisation, consolidation and automation of the technical equipment
- certification of the whole department according to EN ISO 9001: 2008.

Initial situation (Table II)

The initial spatial pattern of the department of laboratory medicine consisted of 594 m² spread over 2 buildings, and in one of these buildings situated on 3 floors. Beside the head of the department, 3 medical specialists for laboratory medicine and transfusion medicine, 32 medical technologists and 1 laboratory assistant were assigned to the department. Per year about 1.730.000 tests were performed, and 4.800 blood products were checked and released by the blood bank. Only the core lab, but not the STAT lab in Enns and the blood bank, was certified to EN ISO 9001: 2008.

Implementation process

Sort: Unnecessary and antiquated methods were removed. Administrative work was shifted from medical technicians to a secretary. Redundancies were eliminated (e.g. blood glucose measurement at the ward was done by technicians as well as by nurses. In agreement with clinicians and nurses this work is now done only by the nurses).

Simplify: Processes were simplified (Figure 1 and 2). Splitting of samples was reduced to a minimum. Samples and materials were clearly assigned ONE working place. Spatial arrangement of working areas with the same demands on employees led to a clear floor plan of the new lab.

Sweep: Serum and plasma samples are sorted (for storage or further processing) automatically by the automation system, reducing the searching. Auto-verification was implemented, focusing the attention on tests that require further investigation.

Standardize: The technical equipment of the core lab (Steyr) and the STAT lab (Enns) were

Table II Benchmark data of the Department of Laboratory Medicine 2006–2010.

	2006		2010	
	Assigned area	Assigned staff	Assigned area	Assigned staff
Assigned area	594 m ²	Spread over 5 places	746 m ²	Spread over 2 places
Assigned staff	Persons	FTE	Persons	FTE
Medical specialists	4	3.5	4	3.5
Medical technologists	32	28.5	34	26.5
	1 person night shift, 2 persons standby (Enns and blood bank)		2 persons night shift, 1 person standby (Enns)	
Laboratory assistant	1	1	1	0.75
Secretary	0	0	1	0.5
Workload			estimated for 2010	
Performed tests	1.730.000		2.250.000	
Checked and released blood products	4.800		5.000	

harmonized. That led to a harmonization of methods, reagents, reference values and processes.

Standard operating procedures (SOP) were written, adjusting the SOPs from the STAT lab to those of the core lab, whenever it was reasonable.

For urine analysis an instrument for automatic generation of urine sediment was connected to the instrument for automated performance of test stripes for urine analysis, leading to a standardized and faster processing of urine analysis

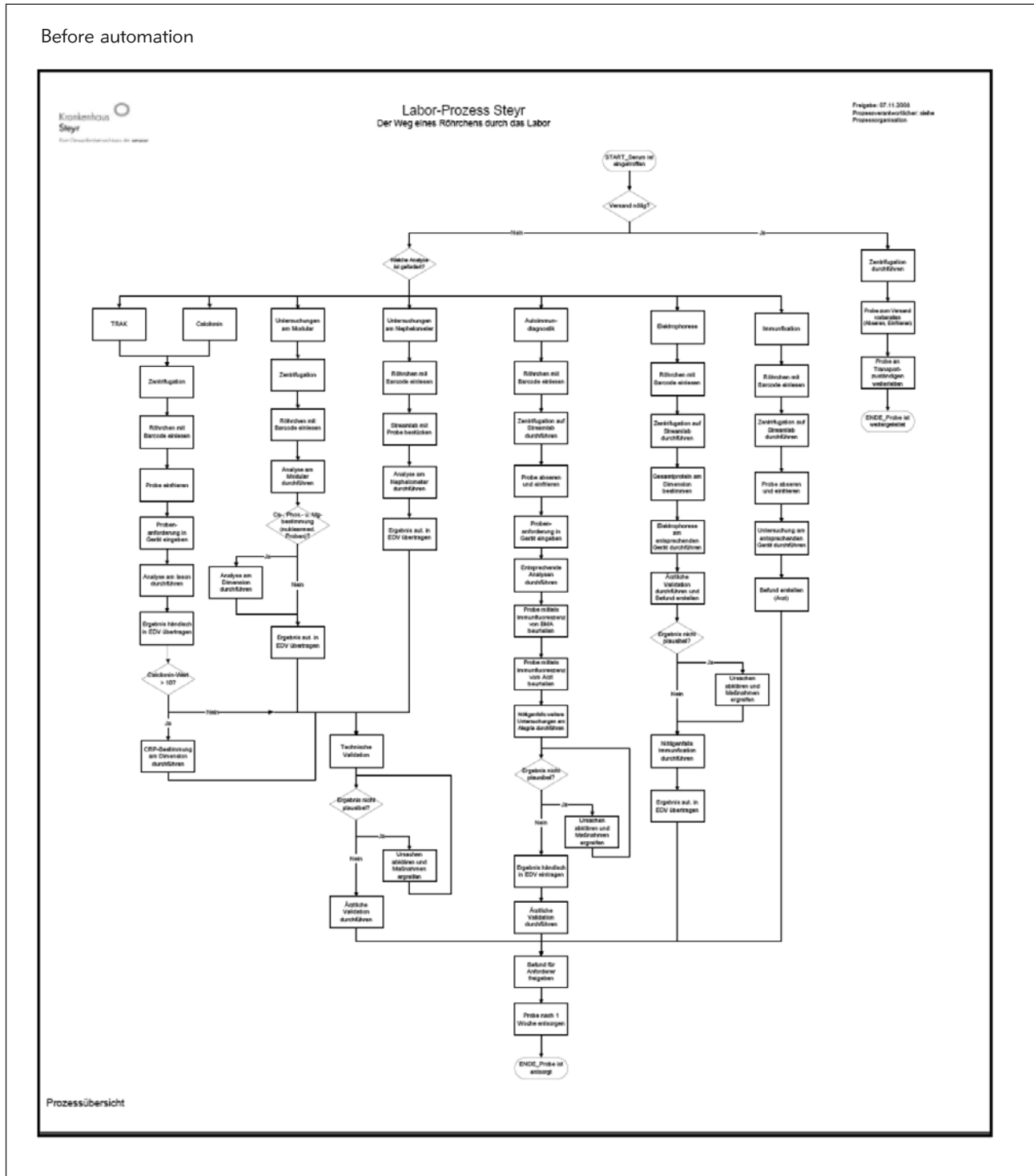

Figure 1a The way of a serum sample through the laboratory before the implementation of automation for clinical chemistry and immunology.

After automation

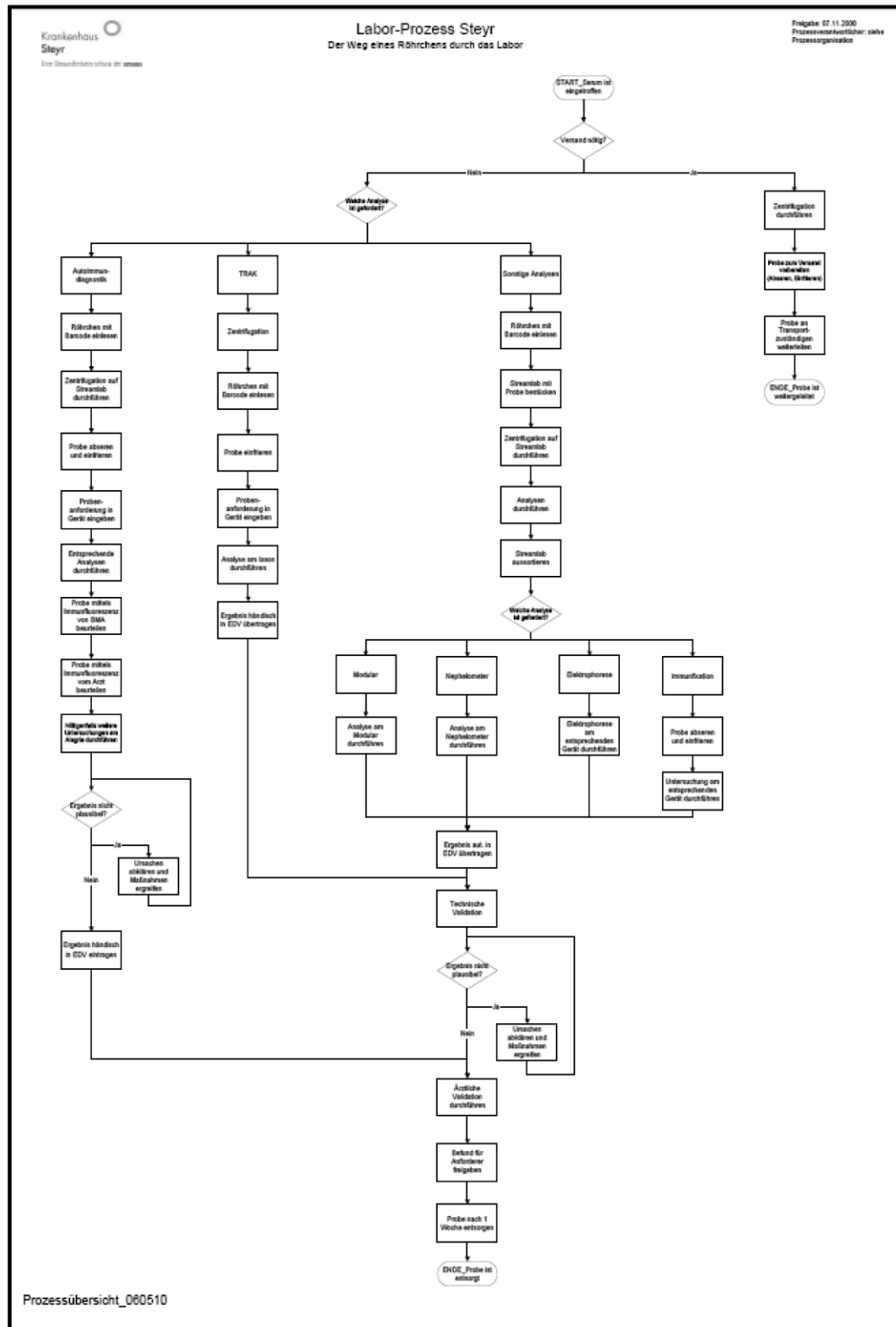

Figure 1b The way of a serum sample through the laboratory after the implementation of automation for clinical chemistry and immunology.

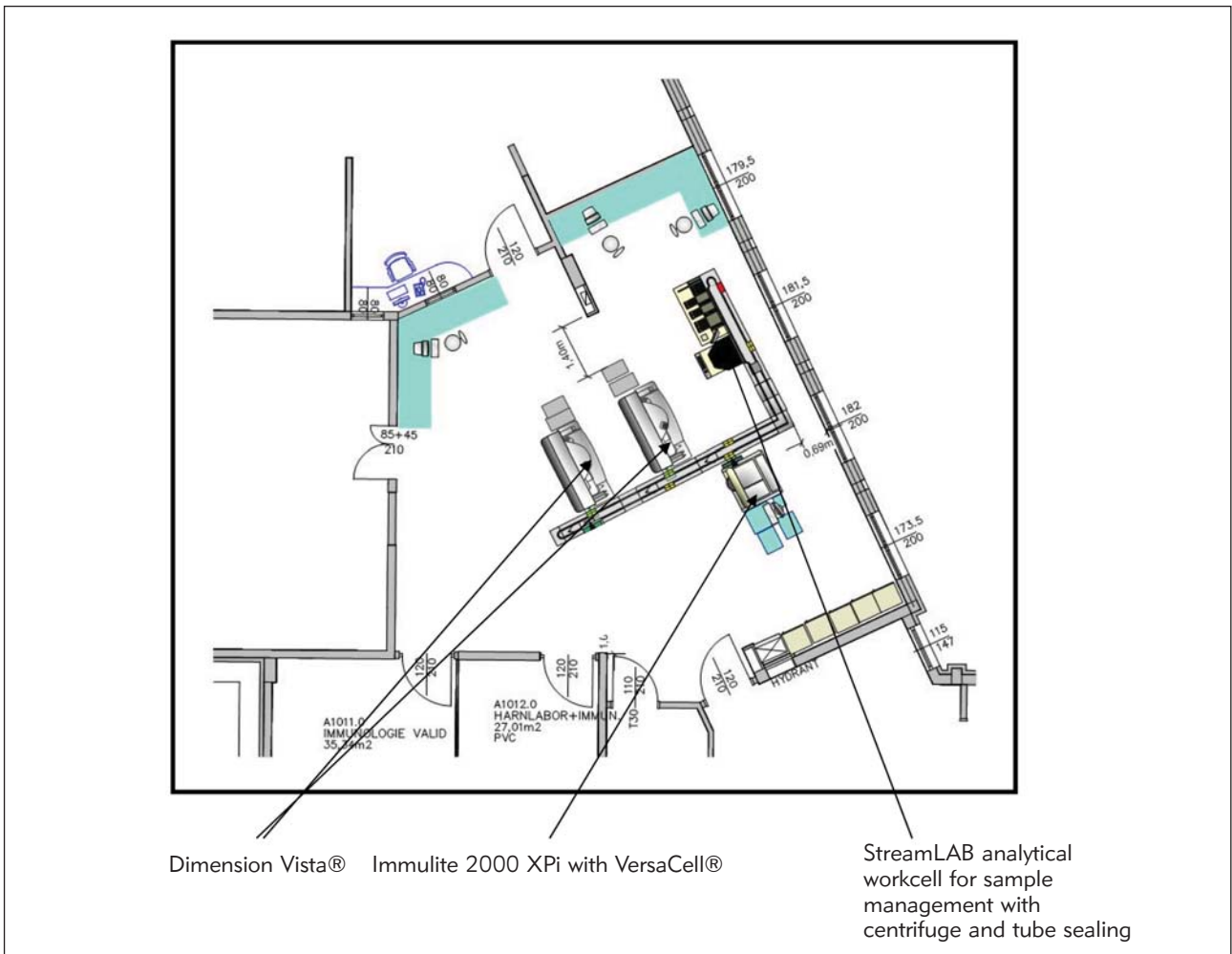

Figure 2 Automation and consolidation of clinical chemistry and immunology, including pre- and postanalytical processes (technical equipment: Siemens Healthcare Diagnostics).

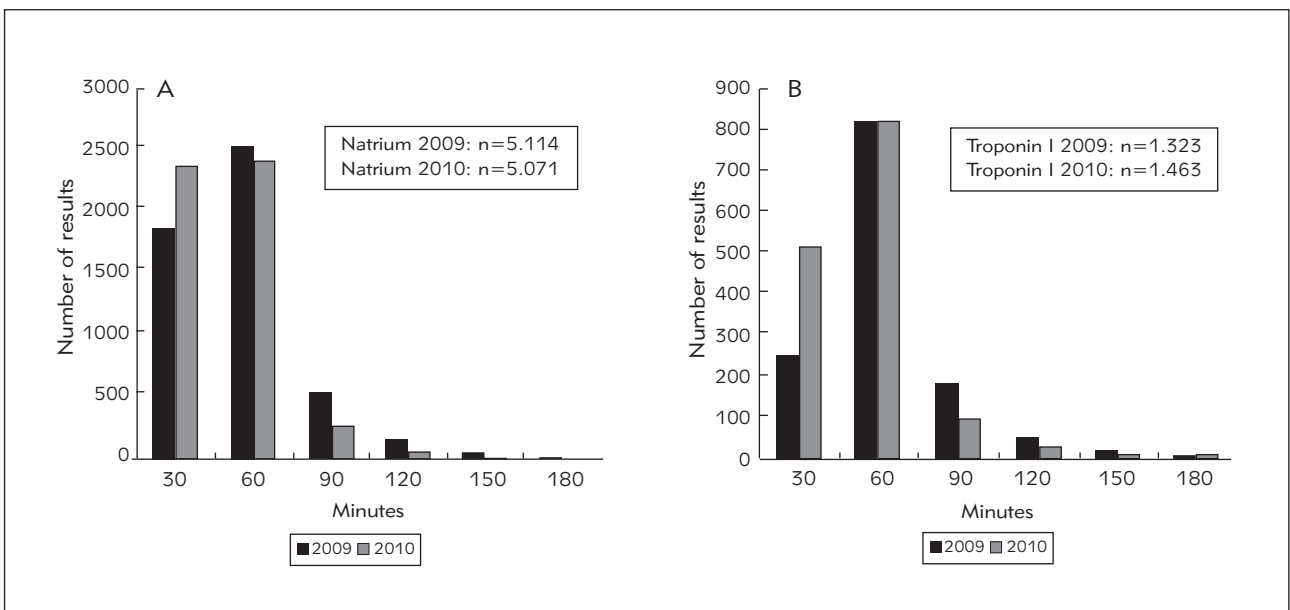

Figure 3 Turnaround time for the parameters natrium (A) and Troponin I (B) before and after automation.

An automated slidemaker and stainer was implemented in the haematology division.

Automation and consolidation of clinical chemistry and immunology, including pre- and postanalytical processes were implemented supporting the standardization of serum and plasma samples processing (Figure 2). Additionally this led to a reduction of manual work done by medical technicians.

Sustain: Internal and external audits are now performed in the whole department of laboratory medicine at least once a year. Management ratios were implemented, allowing the assessment of quality, efficacy, financial development and customers needs.

Present situation (Table II)

Although the workload increased > 30 % in the last four years, there was a total primary cost reduction of 9 %. A reduction of 2 FTE was possible in parallel to the implementation of a second night shift. New parameters concerning the field of molecular diagnosis, autoimmune diagnosis and

sepsis monitoring were implemented. Since January 2010 the Department of Laboratory is situated in the new accommodation. Automation and consolidation of clinical chemistry and immunology led to a reduction of turnaround time (Figure 3).

Conclusion

Lean laboratory organisation lead to improved performance, which has proved beneficial as demands on the laboratory have grown. Our experiences confirmed those of other labs (12, 13, 15): efficacy and turnaround time can be reduced. A decrease in cost despite an increase in demands was possible, making the hospital laboratory competitive with outside labs. Change and evolution of the laboratory will go on, since lean laboratory management is a never-ending process.

Conflict of interest statement

The authors stated that there are no conflicts of interest regarding the publication of this article.

References

1. Kruse-Jarres JD. Labormedizin 2000 – Versuch einer Prognose. *Lab Med* 1994; 18: 213.
2. Felder RA, Graves S, Mifflin T. Reading the future. The increased relevance of laboratory medicine in the next century. *MLO Med Lab Obs* 1999; 31: 20–6.
3. Morger M. Kosten und Finanzierung des Gesundheitswesens. Bundesamt für Statistik, Schweizerische Eidgenossenschaft, Neuchatel 2009.
4. Gesundheit 2008. Statistisches Bundesamt Deutschland, Wiesbaden 2010.
5. Oppolzer EM, Müller MM. Health care system and laboratory medicine in Austria: present status and future perspectives. *Clin Chim Acta* 1999; 290: 37–55.
6. Price CP, Barnes IC. Laboratory medicine in the United Kingdom: 1948–1998 and beyond. *Clin Chim Acta* 1999; 290: 5–36.
7. Markin RS, Whalen SA. Laboratory automation: trajectory, technology, and tactics. *Clin Chem* 2000; 46: 764–71.
8. Battisto DG. Hospital clinical laboratories are in a constant state of change. *Clin Leadersh Manag Rev* 2004; 18: 86–99.
9. Zaninotto M, Plebani M. The »hospital central laboratory«: automation, integration, and clinical usefulness. *Clin Chem Lab Med* 2010; 48: 911–17.
10. Rodrigues S. Guidelines for implementing automation in a hospital laboratory setting – part I. *Clin Leadersh Manag Rev* 2007; 21: E2.
11. Kim CS, Spahlinger DA, Kin JM, Coffey RJ, Billi JE. Implementation of Lean Thinking: one health system's journey. *Jt Comm J Qual Patient Saf* 2009; 35: 406–13.
12. Rutledge J, Xu M, Simpson J. Application of the Toyota Production System improves core laboratory operations. *Am J Clin Pathol* 2010; 133: 24–31.
13. Canković M, Varney RC, Hiteley L, Brown R, D'Angelo R, Chitale D, Zarbo RJ. The Henry Ford Production System: LEAN process redesign improves service in the molecular diagnostic laboratory. *J Mol Diagn* 2009; 11: 390–9.
14. Boat TF, Chao SM, O'Neill PH. From waste to value in health care. *JAMA* 2008; 299: 568–71.
15. Sunyog M. Lean Management and Six-Sigma yield big gains in hospital's immediate response laboratory. *Clin Leadersh Manag Rev* 2004; 18: 255–8.
16. Cote V, Sands N, Hier MP, Black MJ, Tamilia M, MacNamara E, et al. Cost savings associated with post-thyroidectomy parathyroid hormone levels. *Otolaryngol Head Neck Surg* 2008; 138: 204–8.
17. Rand K, Houck H, Lawrence R. Real-time polymerase chain reaction detection of Herpes Simplex virus in cerebrospinal fluid and cost savings from earlier hospital discharge. *J Mol Diagn* 2005; 7: 511–16.
18. Siebert U, Januzzi JL, Beinfeld MT, Cameron R, Gazelle GS. Cost-effectiveness of using N-terminal pro-brain natriuretic peptide to guide the diagnostic assessment and management of dyspneic patients in the emergency department. *Am J Cardiol* 2006; 98: 800–5.

19. Lunau S, editor. Six Sigma and Lean toolset. 2nd ed. Springer-Verlag Berlin Heidelberg New York 2007.
20. Jones D, Mitchell A. Lean thinking for the NHS. NHS Confederation leading edge report 2006.
21. Borgert N. Adapting Lean Management and Six Sigma Techniques in the clinical lab. Clinical Lab Products 2006, www.clpmag.com.
22. Middleton SR. Developing an automation concept that is right for your laboratory. Clin Chem 2000; 46: 75–763.
23. Young DS. Laboratory automation: smart strategies and practical applications. Clin Chem 2000; 46: 740–5.
24. Graves S, Holman B, Felder RA. Modular robotic workcell for coagulation analysis. Clin Chem 2000; 46: 772–7.
25. Holman JW, Mifflin TE, Felder RA, Demers LM. Evaluation of an automated preanalytical robotic workstation at two academic health centers. Clin Chem 2002; 48: 540–8.
26. Plebani M, Piva E. Medical errors: pre-analytical issue in patient safety. Journal of Medical Biochemistry 2010; 29: 310–4.
27. Wing AK. Laboratory automation and optimization: the role of architecture. Clin Chem 2000; 46: 784–91.

Received: July 7, 2010

Accepted: August 19, 2010